

GRAFIK Eye® QS Wireless Control Unit with DALI (CE)

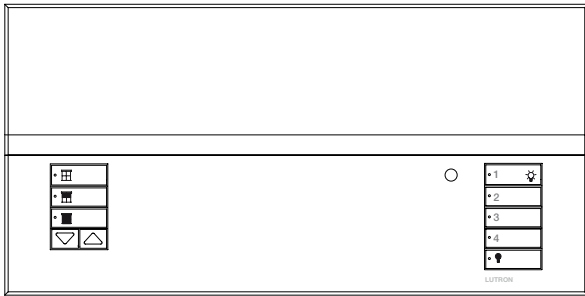

Description

GRAFIK Eye QS Wireless with DALI is the premier energy-saving lighting and shade control. *GRAFIK Eye* QS features an astronomic timeclock, intuitive lighting presets, and direct shade control, which are seamlessly integrated with DALI-compliant output devices, and Lutron's QS components and systems. Now with wireless technology and an integral DALI-compliant bus supply, you can use the *GRAFIK Eye* QS Wireless with DALI to control digital loads and shades without interfaces, and integrate with a variety of Lutron wireless products and systems, including Radio Powr Savr™ occupancy and vacancy sensors, Sivoia® QS Wireless shades, Pico™ wireless control, and other *GRAFIK Eye* QS wireless units. Additionally, the *GRAFIK Eye* QS Wireless is compatible with all Lutron wired QS products and systems.

System Topologies

GRAFIK Eye QS Wireless with DALI can be specified in three different system topologies:

Wired System

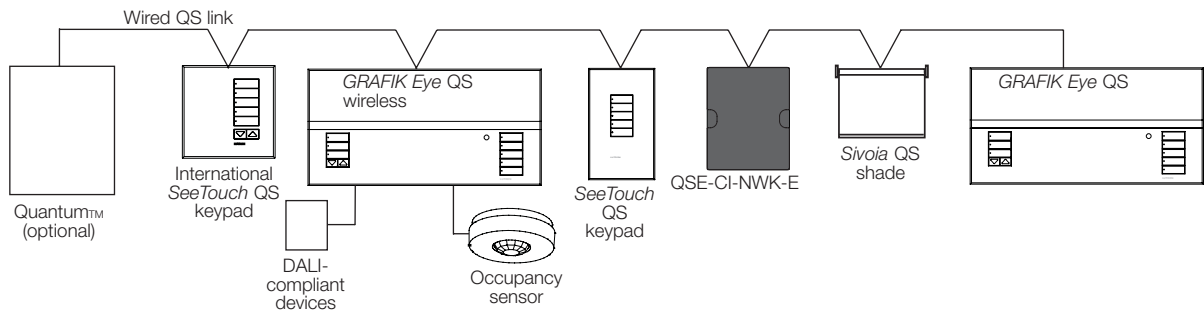

GRAFIK Eye-centric Wireless System

Mixed Wired/GRAFIK Eye-centric Wireless System

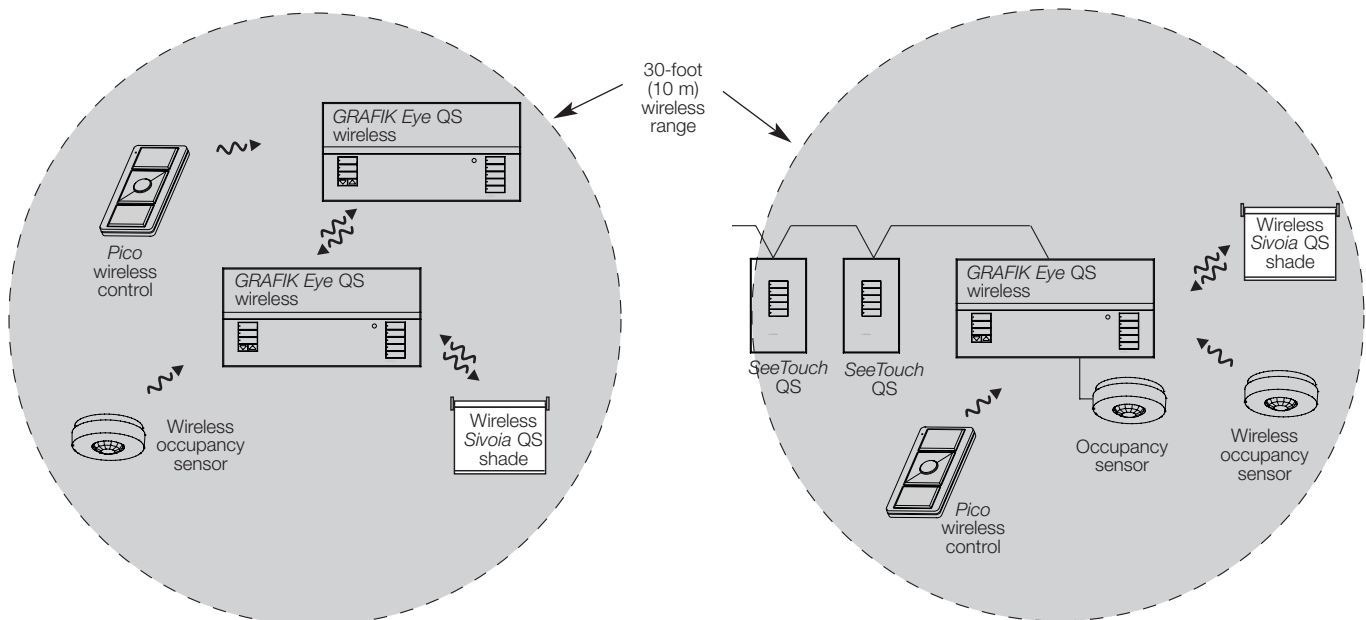

Job Name:	Model Numbers:
Job Number:	

Mechanical Dimensions

Fits into a U.S. 89 mm (3.5 in) deep 4-gang backbox (available from Lutron, P/N 241-400).

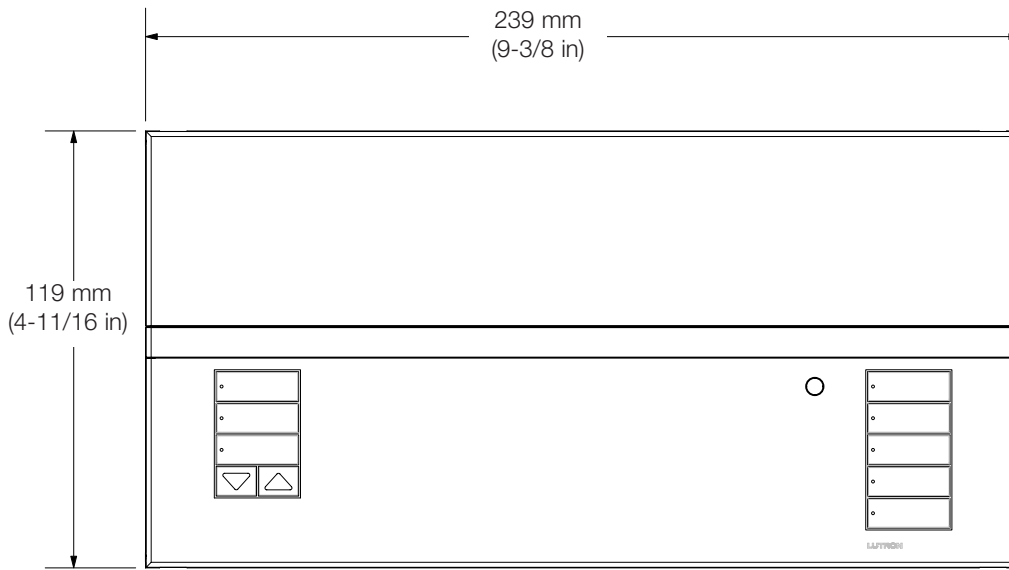

Front View

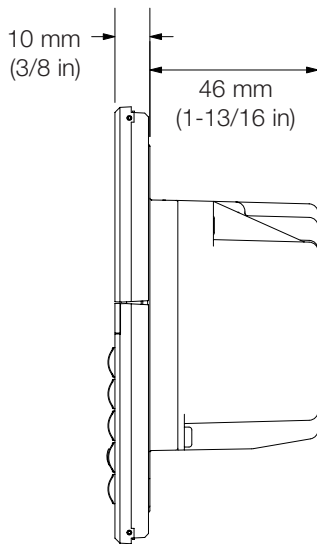

Side View

Job Name:	Model Numbers:
Job Number:	

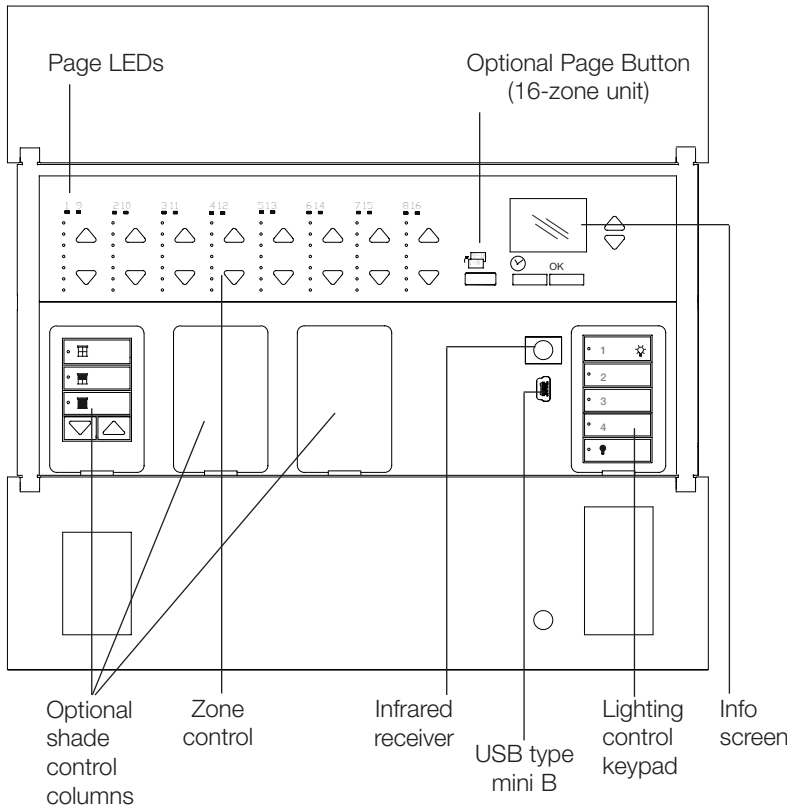

Note: Symbol-based (-SGN) engraving shown.

Features

- Pushbutton recall of four preset lighting scenes, plus Off.
- Twelve (12) additional scenes accessible through other QS devices, such as seeTouch® QS wallstations.
- Optional integrated shade control buttons, which can also be added to the unit after installation.
- Master override buttons to raise and lower all lights.
- Allows setup of lighting scenes and shade presets using buttons on the control unit.
- Built-in infrared (IR) receiver.
- External IR connection.
- Built-in astronomic timeclock.
- Info screen shows zone light level percentage, energy savings, zone labeling, programming, and Digital Addressable Load setup.
- Lockout option prevents accidental changes.
- One occupancy sensor input and 24 V_{DC} power for occupancy sensor.
- QS communication link for seamless integration of lights, motorised window treatments, wallstations, and integration interfaces.
- Compatible with all Lutron QS system components.
- Wireless communication for seamless integration with a variety of Lutron wireless products and systems, including Radio Powr Savr™ occupancy and vacancy sensors, Sivoia® QS wireless shades, PicO™ wireless control, and other *GRAFIK Eye* QS wireless products.
- Control up to 6, 8, or 16 zones of DALI-compliant loads from internal bus supply.
- Up to 64 DALI-compliant output devices can be addressed and grouped into zones.
- Backlit buttons with engraving make unit easy to locate and operate.
- Available in a variety of colours and finishes.

Job Name:	Model Numbers:
Job Number:	

Specifications

Input Power

- 220-240 V \sim 50/60 Hz

Lighting Sources/Load Types

- Up to 64 DALI-compliant output devices (devices must comply with IEC/EN 60929) can be addressed and grouped into zones.
- Before system is addressed, Zone 1 will transmit broadcast commands to all DALI-compliant loads wired to the *GRAFIK Eye QS*.

Key Design Features

- RF meets IEC 801-2.
- Tested to withstand 16 kV electrostatic discharge without damage or memory loss.
- Tested to withstand voltage surges of up to 6000 V \sim and current surges of up to 3000 A. Lightning strike protection meets ANSI/IEEE 62.41-1980 standard.
- Power failure memory automatically restores lighting to the scene selected prior to power interruption, and stores timeclock and scene programming.
- Faceplate is hinged at the top and bottom, and stays open at 180° for ease of access.

Environment

- 0-40 °C (32-104 °F).
- Relative humidity less than 90% non-condensing.

Standards

- CE.
- VDE.
- Certified for IEC/EN compliance.

Scene and Shade Buttons

- Large, rounded buttons are easy to use.
- Backlit buttons with optional engraving make it easy to find and to operate the control unit in low light conditions (backlight can be disabled).
- Optional button engraving is angled up to the eye for easy reading.
- Predefined label stickers are included for field labeling.

Preset Light and Shade Control

- 4 preset lighting scenes, plus Off, are accessible from the front of the control unit.
- 12 additional scenes are stored in the control unit and are accessible from SeeTouch® QS wallstations and QS interfaces.
- Light levels fade smoothly between scenes. Fade time can be set differently for each scene: 0 to 59 seconds, or 1 to 60 minutes. Maximum fade time from Off is 3 seconds.
- Up to 3 columns of shade control.
- Open, preset, close, and raise/lower shade buttons. Each shade column can be programmed to operate one shade or a group of shades.

Zone Control

- Each zone has a dedicated raise and lower button to adjust the zone.
- Each zone has a dedicated 7 LED bar graph for level status. Percentage of light level and energy saved is displayed on the info screen.
- All zone information has blue backlit LEDs. Backlight turns off when idle for 30 seconds.

Info Screen

- OLED (organic LED) screen is viewable from all angles.
- Screen turns off when idle for 30 seconds.
- Programmable zone labels.
- Programmable scene labels.
- Status of real-time zone percentage and energy savings.
- Programmable timeclock schedules.
- Programmable shade labels.

Job Name:	Model Numbers:
Job Number:	

Specifications

Astronomic Timeclock

- Integral to all units.
- 7 daily schedules available.
- One available holiday schedule is programmable by date up to one year in advance.
- 25 events per day maximum.
- Astronomic times are programmable by integral city database or by entering latitude and longitude. Times automatically adjust throughout the year based on location.
- Automatically adjusts for Daylight Saving Time (DST), adjusted for the new dates; DST is programmable.
- Afterhours feature allows occupants to temporarily override timeclock events.

System Communications and Capacities

- Low-voltage type PELV (Class 2: USA) wiring connects control units, wallstations, motorised shades, and control interfaces.
- A QS system can have up to 100 devices and 100 zones (see system limits table on next page).
- A QS system can have up to 30 wireless devices.
- Class 1/Class 2 wiring connects DALI-compliant output devices to control unit.

Infrared

- Infrared (IR) receiver allows infrared transmitters to select 8 scenes, raise/lower lighting zones, or raise/lower shades.
- Transmitter buttons imitate buttons on faceplate.
- 15 m (50 ft) line of sight range.
- Terminal block infrared input for direct contact with external IR connection.
- IR can be disabled via programming.
- Works with Lutron GRX-IT and GRX-8IT infrared remote controllers.

Accessory Controls

- Wired *SeeTouch* QS controls can be added to the control link.
- Each *GRAFIK Eye* QS can power up to 3 wired *SeeTouch* QS controls.

Accessory Controls: Pico® Wireless Control (QSR8P)

- The *Pico* Wireless Control is battery powered. It can control *GRAFIK Eye* QS wireless control units within a 30-foot range. It provides the following features:
 - Control of one or more zones on the *GRAFIK Eye* QS Wireless: turns zone(s) on or off, raises/lowers zone(s), and goes to user-defined preset level
 - Scene control: the *Pico* can access scene 1, scene 16, and Off on the *GRAFIK Eye* QS, and can raise and lower lighting levels

Occupancy Sensor(s)

- The *GRAFIK Eye* QS works with occupancy sensors through either:
 - Scene Control: Up to four sensors activate user-selectable occupancy and vacancy scenes.
 - Zone Control: up to four sensors per zone activate user-selected occupancy and vacancy zone levels.
- Occupancy sensors may include:
 - Contact closure sensor wired to CCI input on back of *GRAFIK Eye* QS
 - Wireless Radio Powr Savr™ occupancy or vacancy sensors (model numbers starting with LRF3)
- If any associated sensor detects occupancy, then the *GRAFIK Eye* QS will go to the designated occupancy level.
- If all associated sensors detect vacancy, then the *GRAFIK Eye* QS will go to the designated vacancy level.

Contact Closure Input (CCI) with Power Supply Output

- Each *GRAFIK Eye* QS has one contact closure input (Terminal A).
 - The attached device must provide a dry contact closure or solid-state output.
 - Input is miswire-protected up to 36 V_{DC}.
- Each *GRAFIK Eye* QS can supply 50 mA maximum at 24 V_{DC}.
 - Useful for powering occupancy sensors.
 - An auxiliary power supply must be used if the device requires more than 50 mA.
- The CCI is capable of operating in the following modes:
 - Occupancy: If an occupancy sensor is wired directly to the *GRAFIK Eye* QS, choose this setting so that the occupancy sensor will work correctly.
 - Emergency: This setting allows the *GRAFIK Eye* QS to work with a LUT-ELI. When an emergency situation is detected, all lights will go to full on, and no operations will be allowed until the emergency signal is cleared.
 - Afterhours: Allows the CCI to start and end the afterhours mode.
 - Timeclock: Allows the CCI to enable and disable the timeclock.
 - Scene Lockout: Prevents the user from making any changes to the control unit. The current scene will stay on until the CCI enables normal operation.
 - Never Save: Prevents any changes from being saved while the CCI is being used.
 - Disable CCI: The CCI will have no effect on the system and will not appear on the list of available sensors.

Job Name:	Model Numbers:
Job Number:	















Specifications

Unit Dissipation

- All models of *GRAFIK Eye QS* Wireless for Digital Addressable Loads dissipate no more than 35 BTUs/hour.

System Limits

- The QS wired communication link is limited to 100 devices (wired or wireless) or 100 zones. Please note the zone count and power unit information in the following table.
- The QS wireless communication link supports up to 30 wireless devices.

QS Device	Zone Count	Power Draw Units (supplied)	Power Draw Units (consumed)
 3-zone <i>GRAFIK Eye QS</i>	3	3	0
 4-zone <i>GRAFIK Eye QS</i>	4	3	0
 6-zone <i>GRAFIK Eye QS</i>	6	3	0
 6-zone <i>GRAFIK Eye QS</i>	6	3	0
 8-zone <i>GRAFIK Eye QS</i>	8	3	0
 16-zone <i>GRAFIK Eye QS</i>	16	3	0
 <i>seeTouch QS</i>	0	0	1
 International <i>seeTouch QS</i>	0	0	1
 <i>Sivoia QS</i>	1	0	1
 Contact closure interface	2	0	3
 Network interface	0	0	2
 DMX interface	0	0	2
 QS smart power panel	0	(Refer to Spec. Submittal)	0
 QS link power supply	0	8	0

Job Name:	Model Numbers:
Job Number:	

GRAFIK Eye QS Wireless for Digital Addressable Loads

Standard Model Numbers

See following pages for Ordering Custom (Non-Standard) Model Numbers

See Standard Colour Combinations page for faceplate, stripe, and button colours

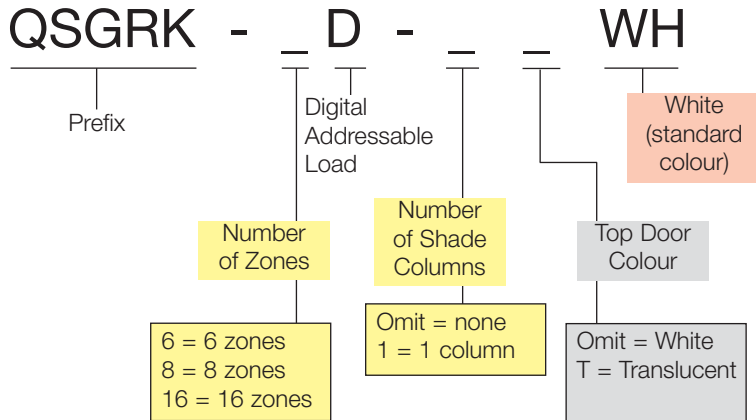

Example:

QSGRK-16D-1TWH

16-zone standard white unit with 1 shade column and translucent top door.

Unit will ship unengraved with engraving certificate that customer can redeem at no charge.

Available Standard Model Numbers

6 Zones	8 Zones	16 Zones
QSGRK-6D-WH	QSGRK-8D-WH	QSGRK-16D-WH
QSGRK-6D-TWH	QSGRK-8D-TWH	QSGRK-16D-TWH
QSGRK-6D-1WH	QSGRK-8D-1WH	QSGRK-16D-1WH
QSGRK-6D-1TWH	QSGRK-8D-1TWH	QSGRK-16D-1TWH

Important Note:

For any non-standard units, you must order **BOTH** a base unit and a Faceplate Kit. Please see the Custom Ordering Information on the following pages.

Job Name:	Model Numbers:
Job Number:	

GRAFIK Eye® QS Wireless for Digital Addressable Loads Custom Options and Model Numbers

See previous pages for Standard and Other Custom Model Numbers

See Standard Colour Combinations page for faceplate, stripe, and button colours

Custom Button Kit

QSGB - 5B - WH -

Custom Button Kit Prefix

Button Configuration

Button Colour/Finish

Keypad Engraving Code

3BRL = 3-button with raise/lower (shade column)
5B = 5-button (lighting keypad)

Button Kit Custom Colour/Finish Codes	Light Almond	LA
Architectural Matte Finishes		
White	WH	
Ivory	IV	
Beige	BE	
Gray	GR	
Brown	BR	
Black	BL	
Almond	AL	
Satin Colour Matte Finishes		
Snow	SW	
Biscuit	BI	
Eggshell	ES	
Taupe	TP	

Keypad Engraving Codes

Omit = Unengraved
Ships with engraving certificate that customer can redeem at no charge

SGN = Symbol-based Engraving

1		
2		
3		
4		

Lighting keypad Shade column

NST = Non-Standard Text Engraving
Please visit the GRAFIK Eye QS website at www.lutron.com/grafikeyeqs for custom engraving forms. Submit completed form with order, and unit will ship engraved as specified by customer.

Custom Stripe Kit

QSGS -

Stripe Kit Prefix

Stripe Colour/Finish

Stripe Custom Colour/Finish Codes
Same as Faceplate colours on previous page

Job Name:	Model Numbers:
Job Number:	

GRAFIK Eye® QS Wireless for Digital Addressable Loads Standard Colour Combinations

See previous pages for Standard and Custom Model Numbers

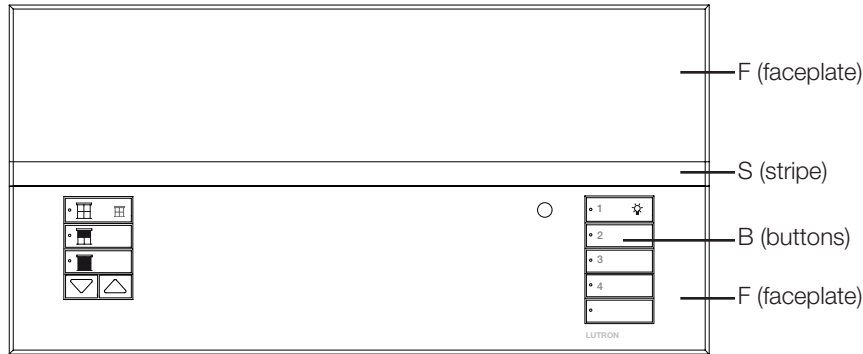

Faceplate is comprised of a top and bottom. The bottom will always be the colour indicated under “faceplate.” The top may be the same colour or translucent. Use the chart for faceplates that have the same colour top and bottom. If a translucent lid is chosen, the stripe will automatically be the same colour as the bottom lid.

Suffix	Faceplate (F)	Stripe (S)	Button (B)	Suffix	Faceplate (F)	Stripe (S)	Button (B)
Architectural Matte				Satin Matte			
WH	White	Gray	White	MN	Midnight	Gray	Black
IV	Ivory	Beige	Ivory	TP	Taupe	Gray	Taupe
BE	Beige	Ivory	Beige	SW	Snow	Gray	Snow
GR	Gray	Black	Gray	ES	Eggshell	Beige	Eggshell
BR	Brown	Black	Brown	BI	Biscuit	Eggshell	Biscuit
BL	Black	Gray	Black	LS	Limestone	Gray	Gray
AL	Almond	Light Almond	Almond	ST	Stone	Gray	Gray
LA	Light Almond	Almond	Light Almond	DS	Desert Stone	Taupe	Taupe
Architectural Metal				TC	Terracotta	Taupe	Taupe
BB	Bright Brass	Black	Black	BG	Bluestone	Gray	Gray
BC	Bright Chrome	Black	Black	HT	Hot	Taupe	Taupe
BN	Bright Nickel	Black	Black	MR	Merlot	Taupe	Taupe
SB	Satin Brass	Black	Black	SI	Sienna	Brown	Brown
SC	Satin Chrome	Black	Black	GB	Greenbrier	Gray	Gray
SN	Satin Nickel	Black	Black	SG	Sea Glass	Gray	Gray
QB	Antique Brass	Black	Black	MS	Mocha Stone	Taupe	Taupe
QZ	Antique Bronze	Black	Black	GS	Goldstone	Ivory	Ivory
Anodized				PD	Palladium	Gray	Gray
CLA	Clear	Black	Black	PL	Plum	Taupe	Taupe
BLA	Black	Black	Black	TQ	Turquoise	Gray	Gray
BRA	Brass	Black	Black				

Job Name:	Model Numbers:
Job Number:	

Overview

Terminations

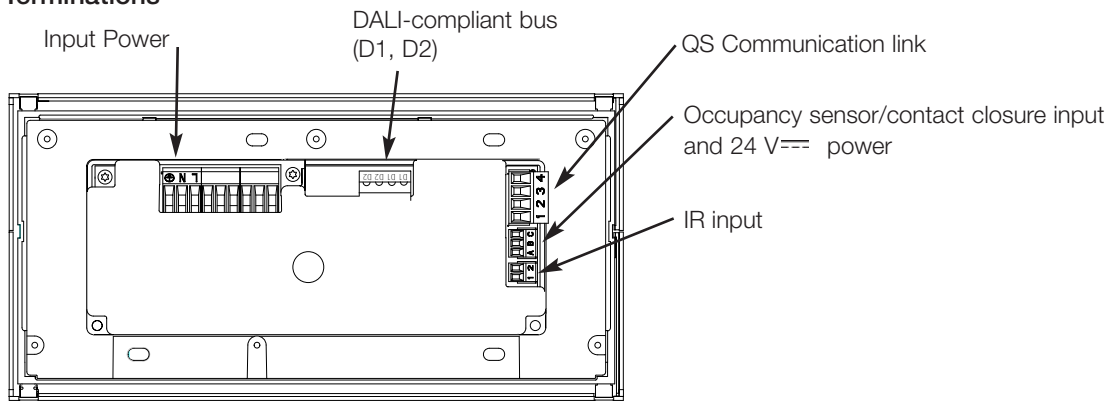

<u>Wire Gauge</u>	<u>Maximum DALI-compliant Bus Wire Length</u>
4.0 mm ² (12 AWG)	671 m (2200 ft)
2.5 mm ² (14 AWG)	427 m (1400 ft)
1.5 mm ² (16 AWG)	275 m (900 ft)
1.0 mm ² (18 AWG)	175 m (570 ft)

Job Name:	Model Numbers:
Job Number:	

PELV (Class 2: USA) QS Communication Link Low-Voltage Wiring

- Each PELV (Class 2: USA) terminal accepts up to two 1.0 mm² (18 AWG) wires.
- Connect the terminal 1, 3, and 4 connections to all control units, wallstations, and control interfaces.
- Each control unit has its own power supply. Terminate the terminal 2 connection (24 V_{DC} power) so that each control unit supplies power to a maximum of three wallstations. Each wallstation should receive power from only one control unit.
- Total length of control link must not exceed 610 m (2000 ft).
- Do not allow PELV (Class 2: USA) wires to contact line/mains wires.

QS Communication Link Terminal Detail

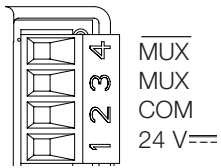

Low-Voltage Wiring Example

Control units shown in rear view

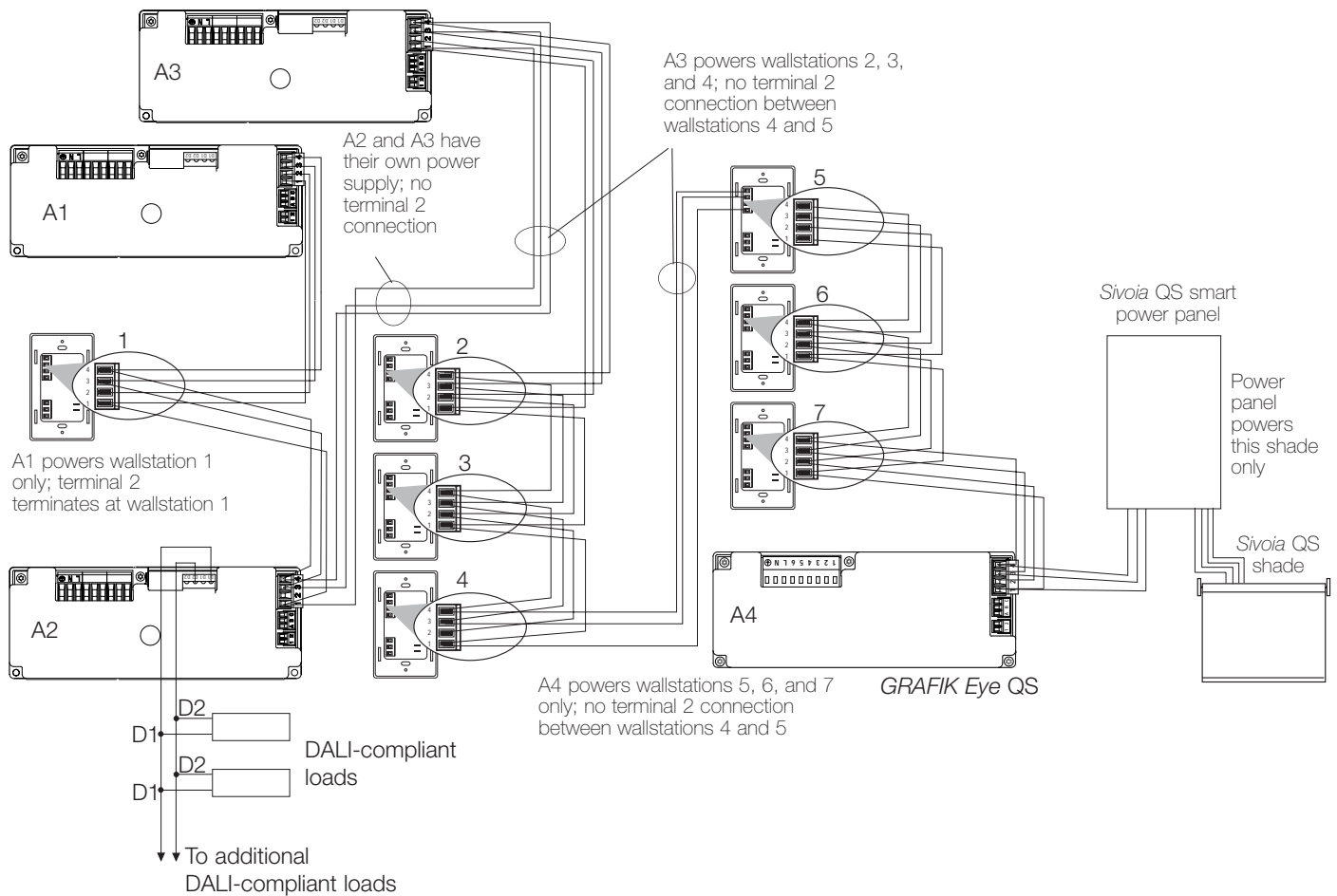

Job Name:	Model Numbers:
Job Number:	

Line Voltage Wiring

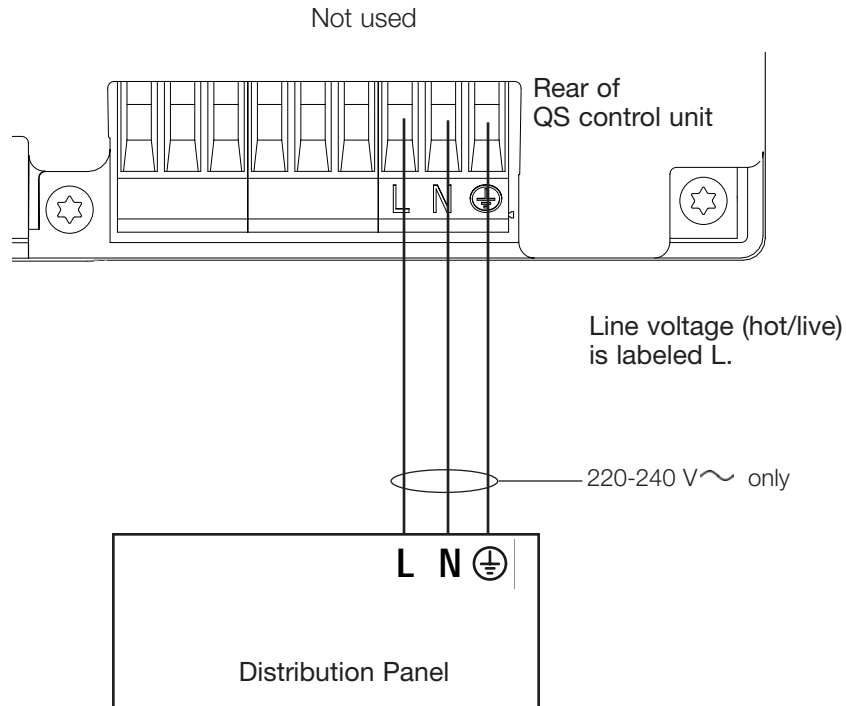

- Pull power wiring from distribution panel and to light fixtures.
- Each line voltage terminal can accept one 2.5 mm² (12 AWG) wire.
- Consult Lutron for non-dim relay wiring and/or load side emergency transfer wiring.

Job Name:	Model Numbers:
Job Number:	

DALI-Compliant Bus Wiring

DALI-Compliant Bus Link Terminal Detail

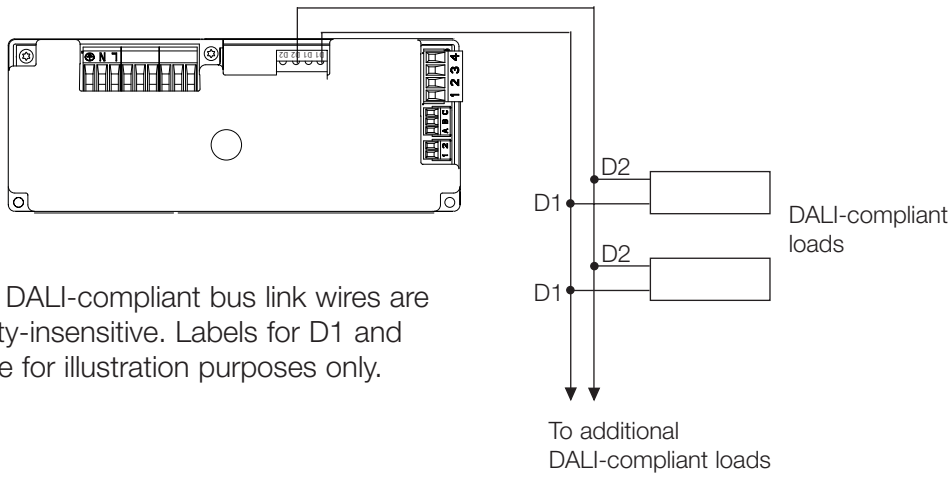

Note: DALI-compliant bus link wires are polarity-insensitive. Labels for D1 and D2 are for illustration purposes only.

DALI-Compliant Bus Wiring Example

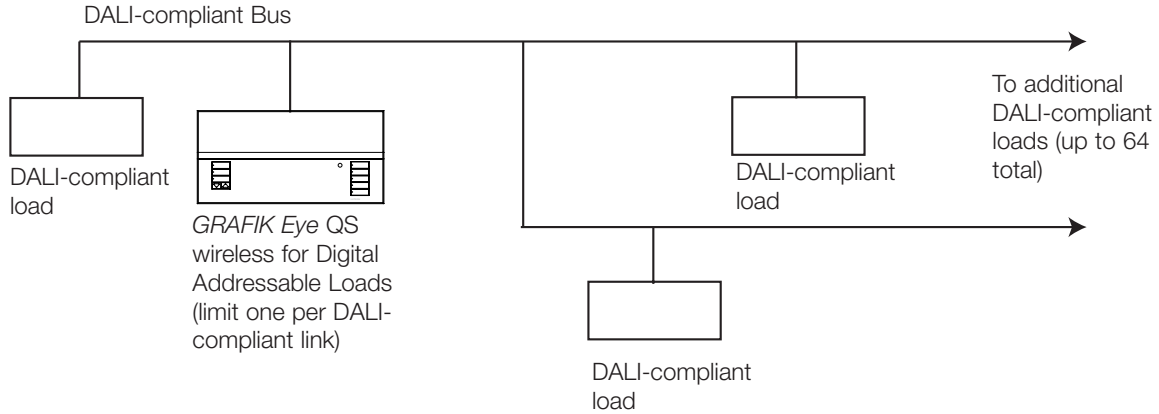

Job Name:	Model Numbers:
Job Number:	

PELV (Class 2: USA) QS Link Wiring

- System communication uses low-voltage wiring.
- Wiring can be daisy-chained or T-tapped.
- Wiring must be run separately from line/mains voltage.
- PELV (Class 2: USA) wiring link requires:
 - Two 1.0 mm² (18 AWG) conductors for control power.
 - One twisted, shielded pair of 1.0 mm² (22 AWG) for data link.
 - Available from Lutron, P/N GRX-CBL-346S; check compatibility in your area.
- Total length of control link must not exceed 610 m (2000 ft).

Daisy-Chain Wiring Example

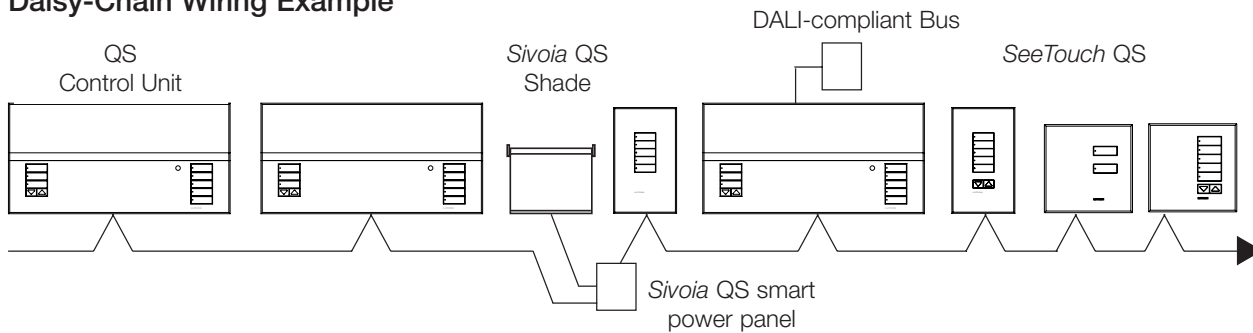

T-Tap Wiring Example

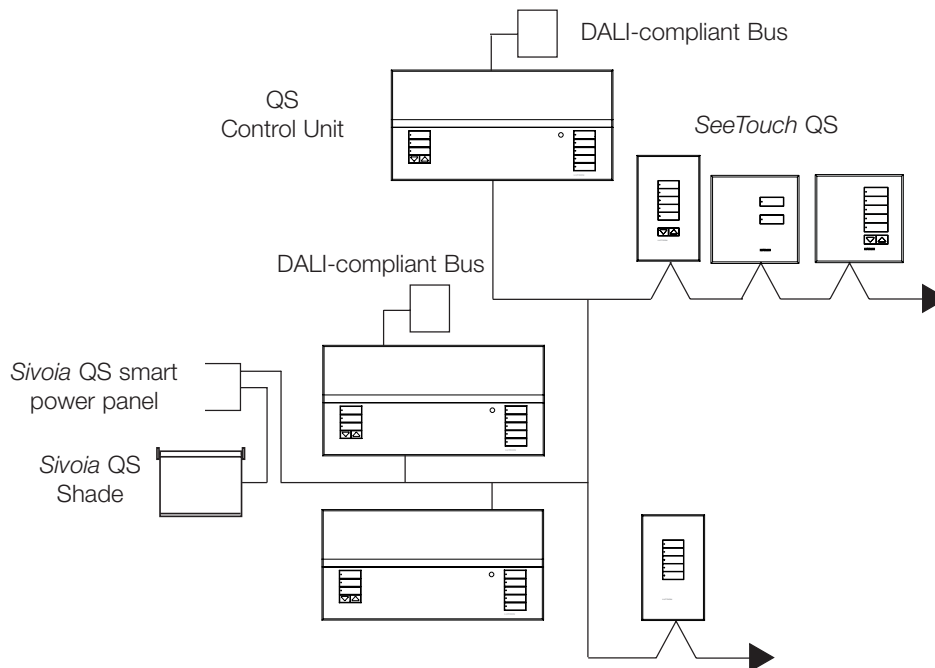

Job Name:	Model Numbers:
Job Number:	

Mounting

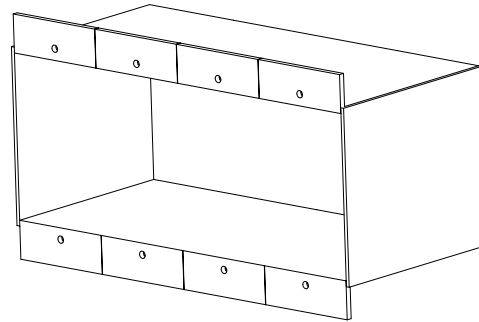

Standard 4-gang
U.S. wallbox,
89 mm (3.5 in) deep
(available from
Lutron, P/N 241-400)

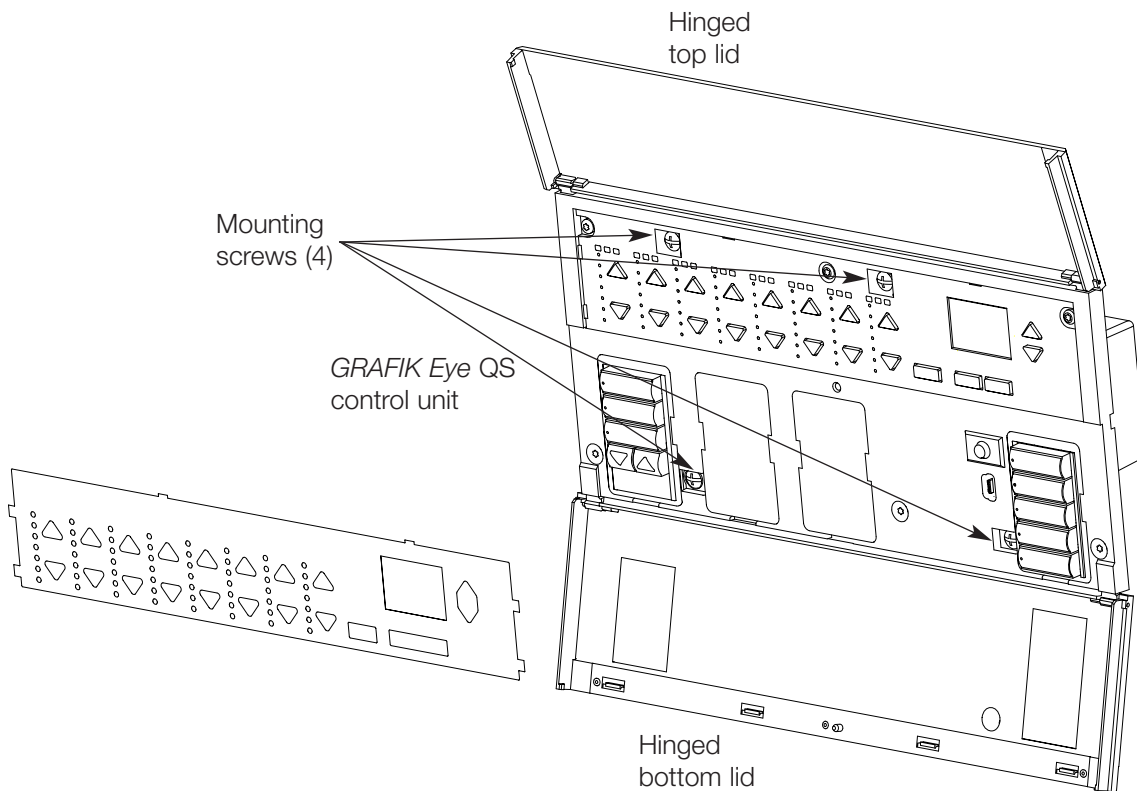

Job Name:	Model Numbers:
Job Number:	